



## 952 BlueOx

### Magnetostrictive LDT for High Shock and Vibration Areas

Gemco brand position sensing products have been known for survival in harsh industrial environments. We have taken over twenty years experience in magnetostrictive linear sensors and married it with our understanding of rugged industrial sensors to develop the BlueOx LDT as the industry's first truly rugged magnetostrictive linear transducer.

The BlueOx LDT is lab tested and field proven to stand up to high shock and vibration. With test results of 2,000 Gs of shock and 30 Gs of random vibration without false signals or mechanical damage, the BlueOx LDT is ready to perform on the most demanding applications.

In addition to its ability to withstand shock and vibration, the BlueOx LDT is rugged in other ways. Sensing tube construction is welded stainless steel, suitable for insertion in 5000 PSI hydraulic cylinders. The electronics are enclosed behind an aluminum housing with O-ring seals for IP67 indoor applications (Type Nema 6 rating and stainless steel covers and connectors are available as a special option).

The 952 BlueOx is available with Analog, Control Pulse, Variable Pulse or RS422 Start/Stop outputs. The 952 is compatible with PLC interface cards and our 1746 LDT Interface Card. The 16 bit resolution analog output is programmable over the entire active stroke length. The units can easily be changed in the field from a 0 - 10 VDC to a 10 - 0 VDC or a 4 - 20mA to a 20 - 4mA. As an added feature, the optional differential analog output allows the distance between two magnets to be measured.

The BlueOx, with its high resolution and rugged construction, is at home in heavy duty areas such as lumber mills, steel mills, stamping plants, assembly automation, material handling, robotics and any other industry where highly accurate and reliable continuous linear position sensing is needed.



952

Specifications	
Input Voltage	Analog: 13.5 to 30 VDC Digital: 13.5 to 26.4 VDC, or +/- 15 VDC
Current Draw	< 200mA at 15 VDC
Output	Analog: 0 to 10 VDC or 10 to 0 VDC, 4 to 20mA or 20 to 4mA Digital: Start/Stop, Control Pulse or Pulse-Width Modulated/ Variable Pulse (PWM/VP)
Resolution Internal Analog Output	0.001" 16 Bit (1 part in 65,535)
Linearity	+/-0.05% of Full Scale
Repeatability	+/-0.006% of Full Scale (+/- .002 inch min.)
Hysteresis	+/-0.02% of Full Scale
Operating Temperature Head Electronics Guide Tube	-40° to 158° F (-40° to 70° C) -40° to 221° F (-40° to 105° C)
Operating Pressure	5000 psi Operational, 10,000 psi Spike
Span Length	2" to 168"
Null Zone	2"
Dead Band	2.5"
Connectors	12mm Micro 5 Pin, CE Approved (Analog Only), 10 Pin 1/4 Turn MS Connector, Potted Pigtail Assembly, Optional Temposonics II & III Connectors
Update Time Analog	1ms (Stroke Lengths 1" to 50") 2ms (Stroke Lengths 51" to 100") 3ms (Stroke Lengths 101" to 150") 4ms (Stroke Lengths 151" to 168") Controller Dependent
Digital	
Enclosure	IP67
Approvals	CE ( Analog 12mm Micro 5 Pin Connector Only )
Specifications are subject to change without notice. Specifications are based on a typical 36" LDT .	

### Dimension Drawing

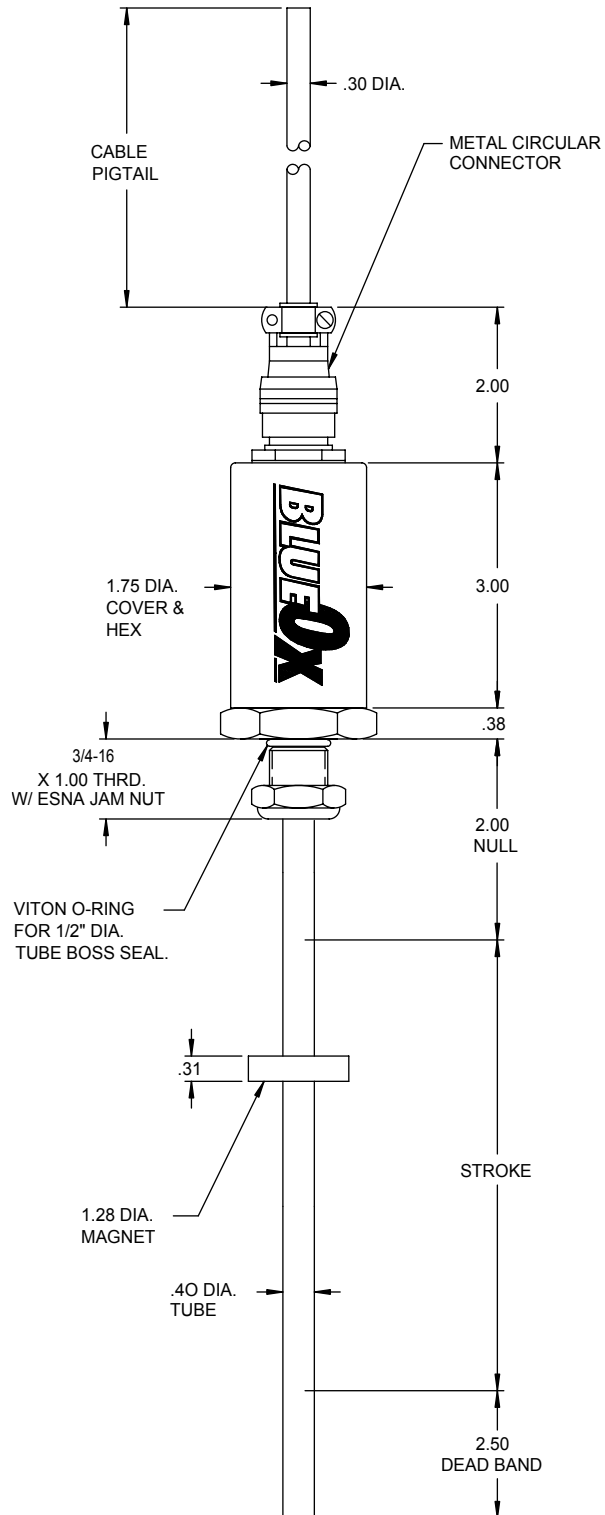



# 952A BlueOx

## Part Numbering

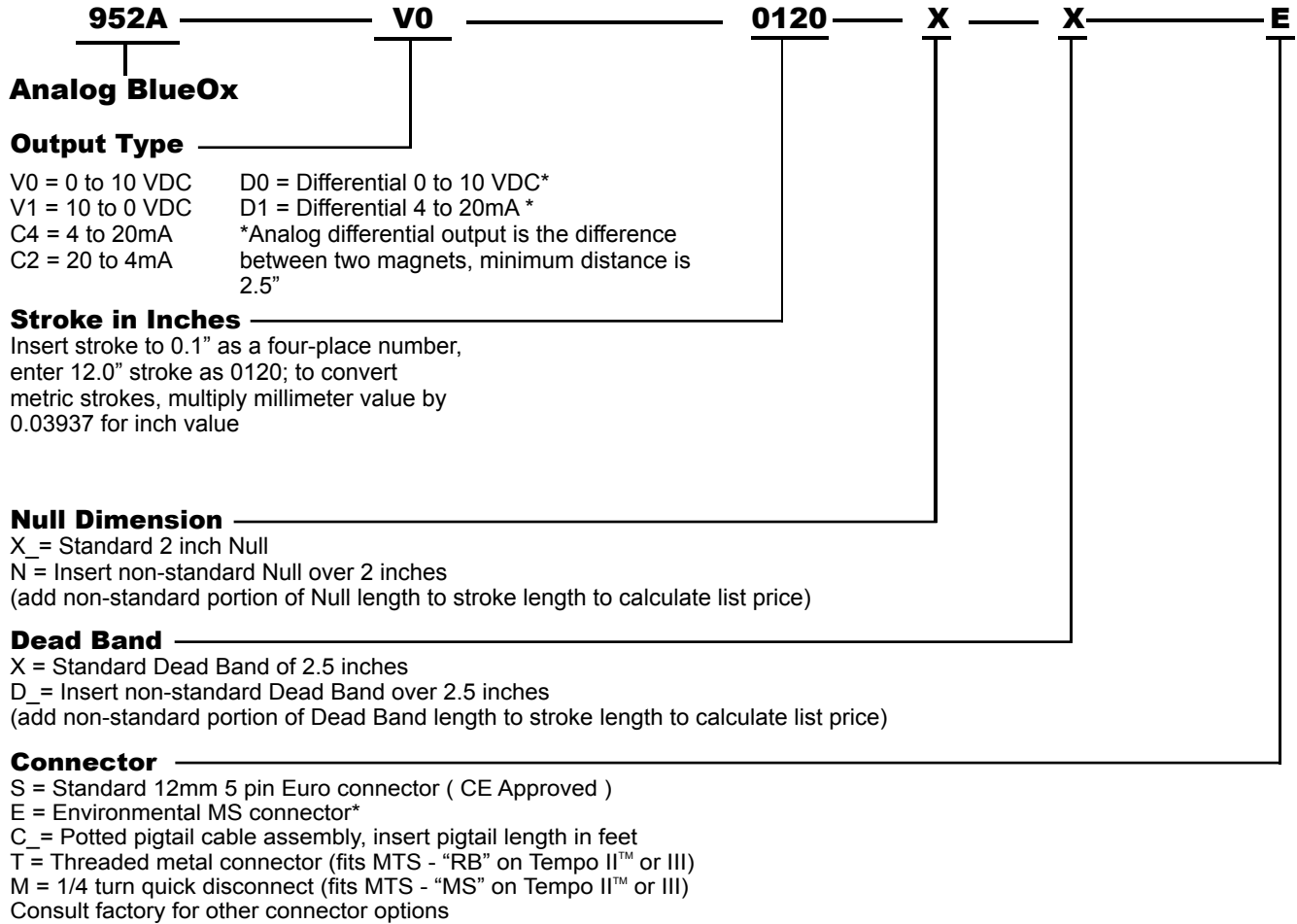

952

\* If option S or E (environmental connector) is selected, mating connector and/or pigtail must be ordered separately.

**Note 1:** On unsupported stroke lengths greater than 4 feet, rod support bracket(s) and a special magnet should be used.

**Note 2:** Specify magnet as separate line item (standard magnet is SD0400800).

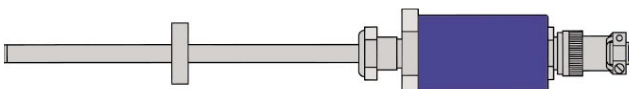
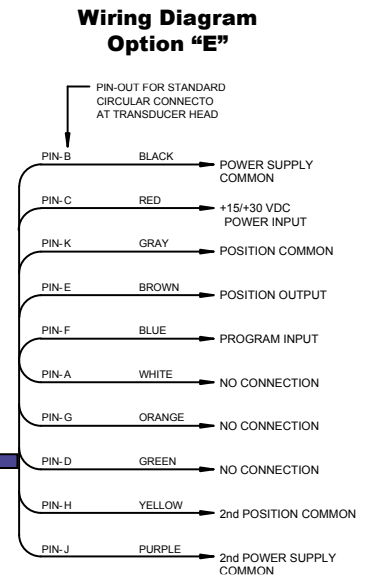
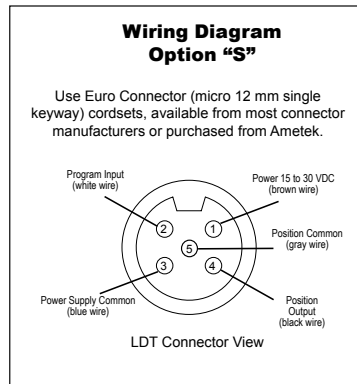

## Part Numbering

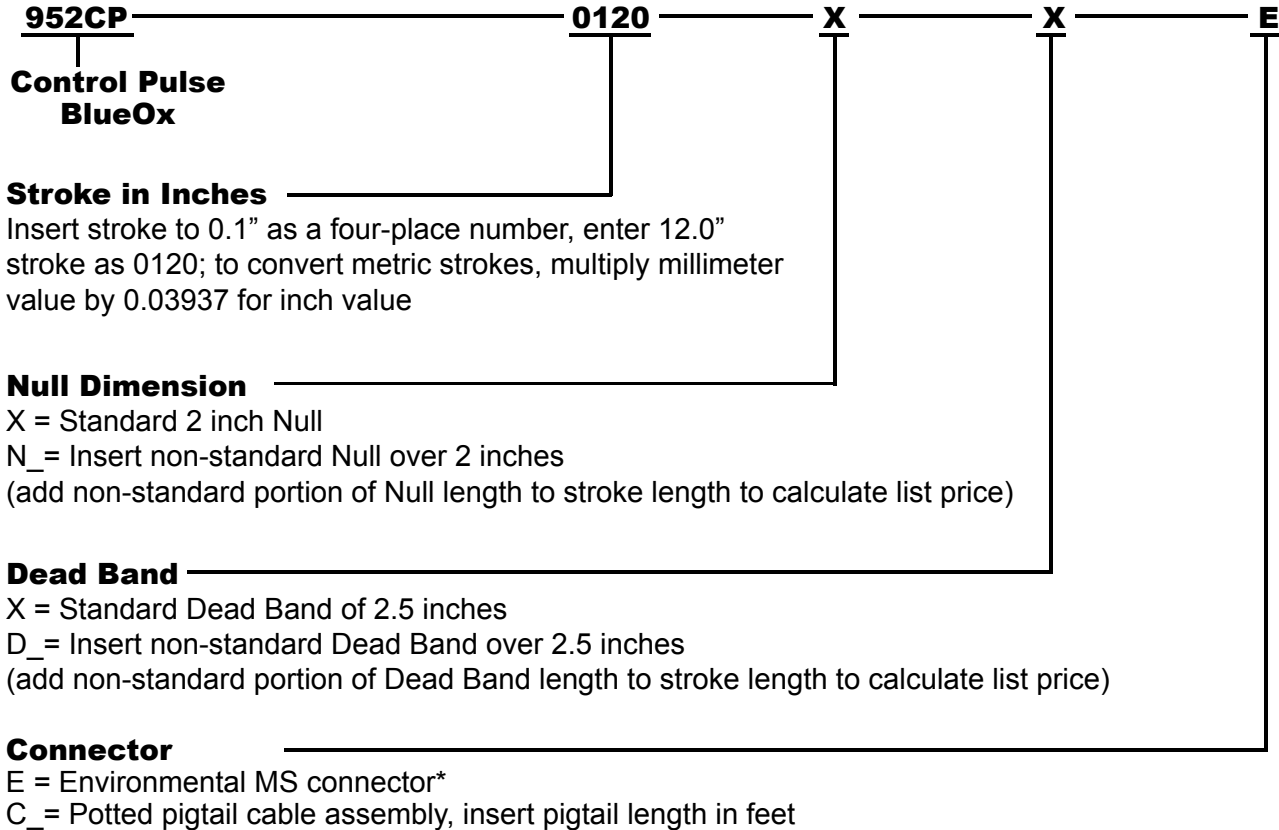

952

## Wiring Diagram

\* If option E (environmental connector) is selected, mating connector and/or pigtail must be ordered separately.

**Note 1:** On unsupported stroke lengths greater than 4 feet, rod support bracket(s) and a special magnet should be used.

**Note 2:** Specify magnet as separate line item (standard magnet is SD0400800).

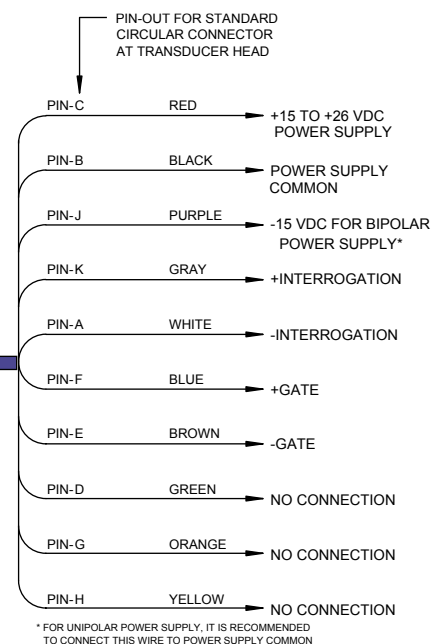
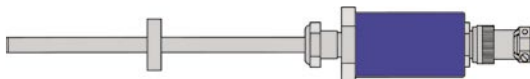



# 952VP BlueOx

## Part Numbering

**952VP** ————— **0120** ————— **X** — **X** ————— **E** ————— **I** ————— **001**

**Variable Pulse BlueOx**

### Stroke in Inches

Insert stroke to 0.1" as a four-place number, enter 12.0" stroke as 0120; to convert metric strokes, multiply millimeter value by 0.03937 for inch value

### Null Dimension

X = Standard 2 inch Null  
 N\_ = Insert non-standard Null over 2 inches (add non-standard portion of Null length to stroke length to calculate list price)

### Dead Band

X = Standard Dead Band of 2.5 inches  
 D\_ = Insert non-standard Dead Band over 2.5 inches (add non-standard portion of Dead Band length to stroke length to calculate list price)

### Connector

E = Environmental MS connector\*  
 C\_ = Potted pigtail cable assembly, insert pigtail length in feet  
 T = Threaded metal connector (fits MTS - "RB" on Tempo II™ or III)  
 M = 1/4 turn quick disconnect (fits MTS - "MS" on Tempo II™ or III)

### Interrogation Mode

I = Internal interrogation  
 E = External interrogation

### Recirculations Required

001 (standard) to 127

\* If option E (environmental connector) is selected, mating connector and/or pigtail must be ordered separately.

952

## Wiring Diagram

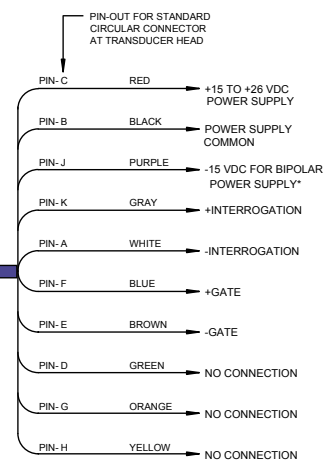

**Note 1:** On unsupported stroke lengths greater than 4 feet, rod support bracket(s) and a special magnet should be used.

**Note 2:** Specify as magnet separate line item (standard magnet is SD0400800).

\* FOR UNIPOLAR POWER SUPPLY, IT IS RECOMMENDED TO CONNECT THIS WIRE TO POWER SUPPLY COMMON

## Part Numbering

**952RS** ————— **0120** ————— **X** ————— **X** ————— **E**

**RS422 Start/Stop with Interrogation Start Sequence Pulse BlueOx**

### Stroke in Inches

Insert stroke to 0.1" as a four-place number, enter 12.0" stroke as 0120; to convert metric strokes, multiply millimeter value by 0.03937 for inch value

### Null Dimension

X = Standard 2 inch Null  
 N\_ = Insert non-standard Null over 2 inches (add non-standard portion of Null length to stroke length to calculate list price)

### Dead Band

X = Standard Dead Band of 2.5 inches  
 D\_ = Insert non-standard Dead Band over 2.5 inches (add non-standard portion of Dead Band length to stroke length to calculate list price)

### Connector

E = Environmental MS connector\*  
 C\_ = Potted pigtail cable assembly, insert pigtail length in feet  
 T = Threaded metal connector (fits MTS - "RB" on Tempo II™ or III)  
 M = 1/4 turn quick disconnect (fits MTS - "MS" on Tempo II™ or III)

\* If option E (environmental connector) is selected, mating connector and/or pigtail must be ordered separately.

**Note1:** On unsupported stroke lengths greater than 4 feet, rod support bracket(s) and a special magnet should be used.

**Note 2:** Specify magnet as separate line item (standard magnet is SD0400800).



## Wiring Diagram

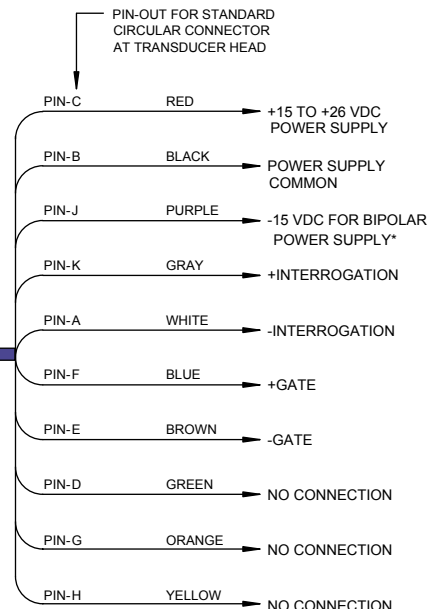

\* FOR UNIPOLAR POWER SUPPLY, IT IS RECOMMENDED TO CONNECT THIS WIRE TO POWER SUPPLY COMMON



# 952QD BlueOx with Quadrature Output

## Magnetostrictive LDT with Quadrature Output

The BlueOx Quadrature is a magnetostrictive linear displacement transducer (LDT) for continuous machine positioning in a variety of industrial applications. The quadrature output makes it possible for customers to have a direct interface to virtually any incremental encoder input or counter card, eliminating costly absolute encoder converters and special PLC interface modules.

The BlueOx Quadrature LDT is lab tested and field proven to stand up to high shock and vibration without effect. With test results of 2,000 Gs of shock and 30 Gs of random vibration without false signals or mechanical damage, the BlueOx Quadrature LDT is ready to perform in the most demanding applications.

The BlueOx Quadrature LDT can be ordered with 1 to 9999 cycles per inch of output resolution and the position data is absolute. The transducer features an input to re-zero the probe “on the fly”. Another unique feature is the “burst” mode. An input on the transducer triggers a data transfer of all the incremental position data relative to the transducer’s absolute zero position. This can be used to achieve absolute position updates when power is restored to the system.

The BlueOx Quadrature is shipped from the factory pre-calibrated and ready for installation. In addition to its ability to withstand shock and vibration, the BlueOx Quadrature is rugged in other ways. Sensing tube construction is welded stainless steel, suitable for insertion in 5,000 PSI hydraulic cylinders.

The electronics are enclosed behind an aluminum housing with O-ring seals. The BlueOx Quadrature LDT, with its rugged construction, is at home in heavy duty areas such as lumber mills, steel mills, stamping plants and any other harsh environment where accurate and reliable continuous linear position sensing is needed.



952

Specifications	
Input Voltage	13.5 to 26.4 VDC
Current Draw	< 200mA at 15 VDC
Output	Quadrature Output A+, A-, B+, B-, Z+, Z-. Line Drivers: 5V or Input Power
Inputs	10 to 30 VDC
Resolution	0.001"
Linearity	<.05% (+/- .002" Min)
Repeatability	0.001% of Full Stroke (+/- .002" Min.)
Hysteresis	+/- .02% of Full Scale
Operating Temperature Head Electronics Guide Tube	-40° to 155° F (-40° to 70° C) -40° to 220° F (-40° to 105° C)
Operating Pressure	5000 PSI Operational, 10,000 PSI Spike
Span Length	2" to 168"
Null Zone	2.0"
Dead Band	2.5"
Connectors	1/4 Turn MS Connector Standard. Potted Pigtail Assembly Available Optionally
Update Time	Approx. 1ms for < 60" Approx. 2ms for > 60" to < 120" Approx. 3ms > 120"
Enclosure	IP67
Specifications are subject to change without notice. Specifications are based on a typical 36" LDT.	

## Dimension Drawing

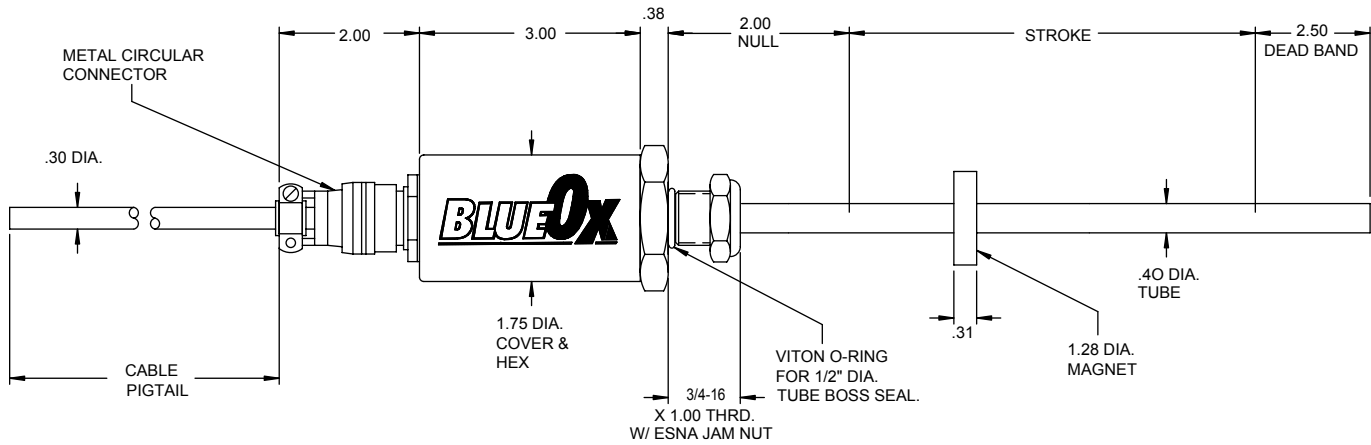

952

## Wiring Diagram

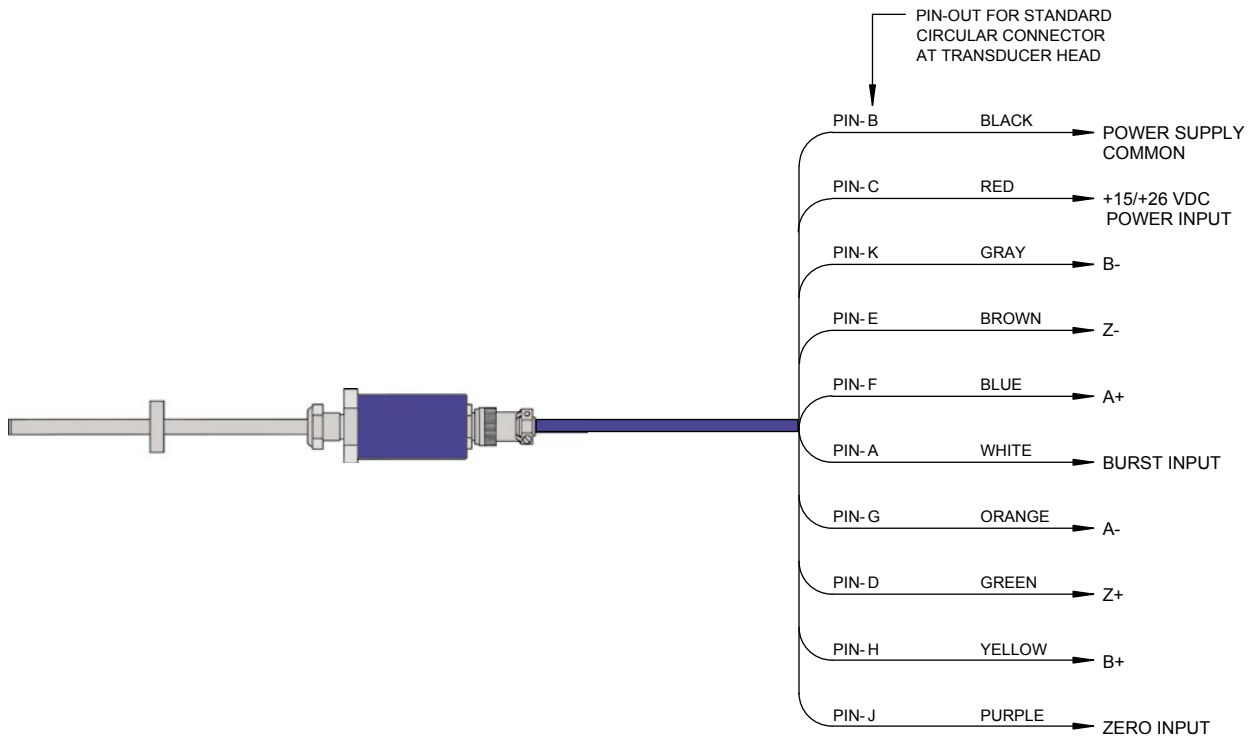



# 952QD BlueOx with Quadrature Output

## Part Numbering

**952QD** — **0120** — **X** — **X** — **E** — **1000** — **E** — **F7** — **M1** — **N** — **D** — **X**

**BlueOx with Quadrature Output**

### Stroke in Inches

Insert stroke to 0.1" as a four-place number, enter 12.0" stroke as 0120; to convert metric strokes, multiply millimeter value by 0.03937 for inch value

### Null Dimension

X = Standard 2 inch Null  
N\_ = Insert non-standard Null over 2 inches (add non-standard portion of Null length to stroke length to calculate list price)

### Dead Band

X = Standard Dead Band of 2.5 inches  
D\_ = Insert non-standard Dead Band over 2.5 inches (add non-standard portion of Dead Band length to stroke length to calculate list price)

### Connector

E = Environmental MS connector\*  
C\_ = Potted pigtail cable assembly, insert pigtail length in feet

### Output Resolution

Cycles per inch, maximum internal resolution is 0.001 inches  
1000 standard (available range is 0001 through 9999)

### Input Type

E = Sinking (typically used with sourcing output type)  
C = Sourcing (typically used with sinking output type)  
T = TTL Level

### Quadrature Cycle Output Frequency Range

F1 = 10 KHz F2 = 25 KHz F3 = 50 KHz F4 = 75 KHz  
F5 = 100 KHz F6 = 150 KHz F7 = 250 KHz F8 = 500 KHz F9 = 1.00 MHz

### Output Mode

M1 = X1 quadrature, consult factory for other output modes

### Zero Offset Storage

V = Volatile (non retentive)  
N = Nonvolatile (retentive, 100,000 storage cycles maximum)

### Output Drivers

D = Differential RS422 line driver, TTL compatible  
L = Differential line driver 10 to 30 VDC, V out = V in (LDT Power) -1 Volt

### Options

X = None

\* If option E (environmental connector) is selected, mating connector and/or pigtail must be ordered separately.